

It's simple: The cutter that grows with your business.

Advantages of a modular system.

New trends and ever-changing customer demands are defining the market. In such a fast-paced environment, the modularity of the Zünd cutter keeps you in the game. It gives you a system that will grow right along with your needs, whether you want to upgrade to another tool for added cutting capabilities or increase efficiency with different levels of automation. The configurations below are just a few examples of all the possible variations.

MANPOWER

manual

manual

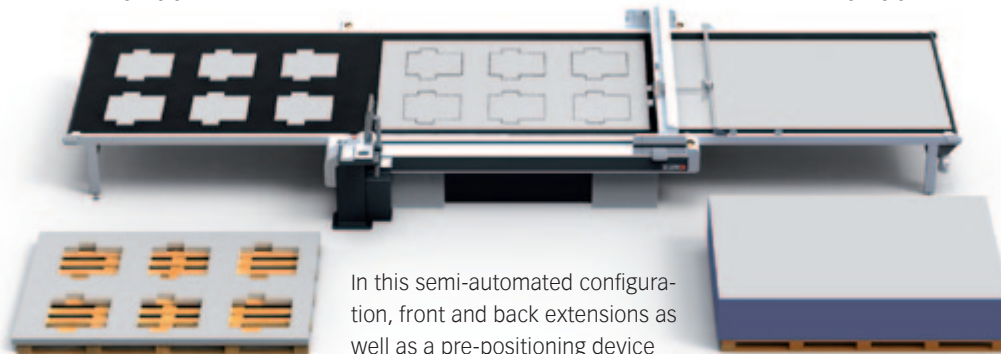

In this semi-automated configuration, front and back extensions as well as a pre-positioning device are added to the cutter; this setup maximizes throughput by allowing for removal/inspection of cut parts and loading the next board without interrupting the cutting process.

manual

automated

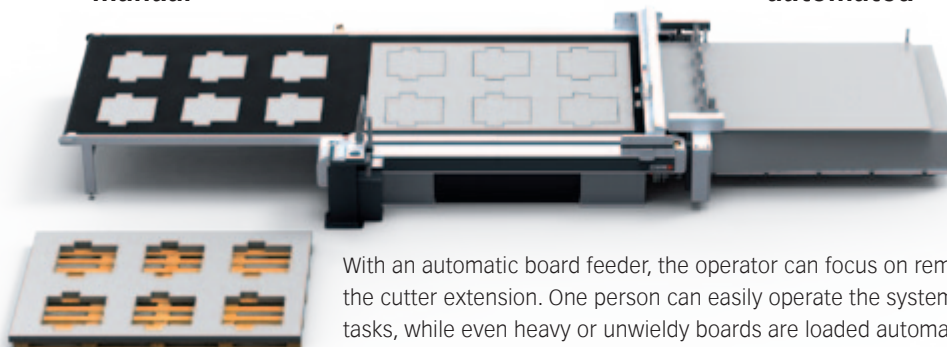

With an automatic board feeder, the operator can focus on removing cut parts from the cutter extension. One person can easily operate the system and attend to other tasks, while even heavy or unwieldy boards are loaded automatically.

automated

automated

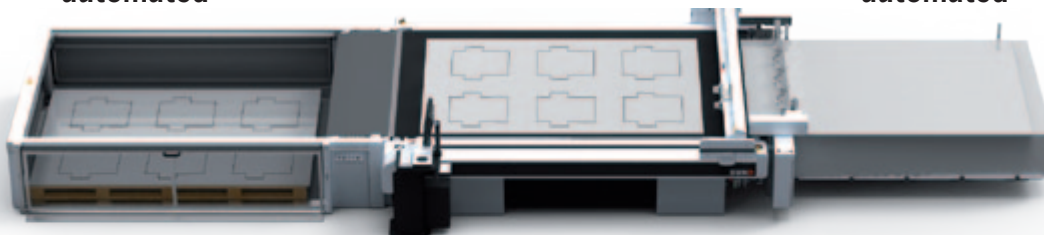

The highest level of automation includes automatic board feeding for loading, automatic stacking for off-loading. Manpower requirements are reduced to job setup, and delivery/removal of stacked boards. With this setup, it is possible to run the cutter without an operator in attendance.

EFFICIENCY

Headquarter
Zünd Systemtechnik AG
Industriestrasse 8
CH-9450 Altstätten
T +41 71 757 81 00
F +41 71 757 81 11
info@zund.com
www.zund.com

ZÜND
swiss cutting systems

Digital cutting productivity at its best.
G3 fully automated, unattended.



Efficiency through modularity.
Automation on demand.

Expanding capacity with less manpower.

The Zünd G3 cutting system with automatic board loading and unloading provides display, signage, and packaging companies with the ultimate in automation. What this means is minimal labor requirements, limited to the delivery and removal of stacked materials. Unattended cutting operations during off-hours become routine. Formats up to 2x3 m (6.5x10 ft) can be processed, corrections and changes made right up to the start of a production run. Consistent with the Zünd philosophy: completely modular automation that can be built up and retro-fitted as needed. Naturally, the system also allows for efficient just-in-time production of shorter runs and even one-offs.

No bridges necessary

A unique transport system allows for reliable stacking of cut boards without the need for bridges to hold cut pieces in place. The result: separating finished pieces from waste becomes considerably easier and more efficient.

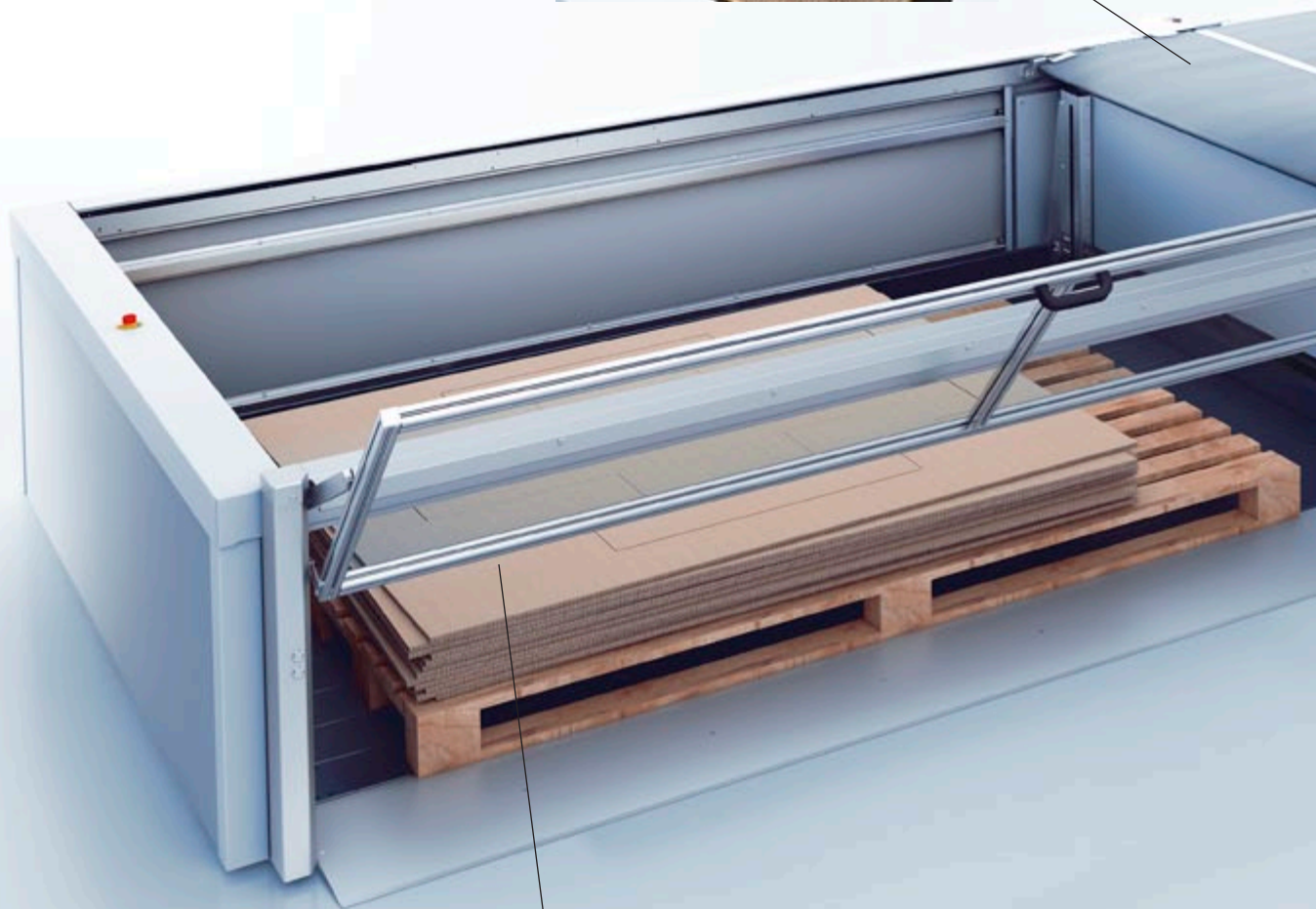

Board off-loading/Board staker

Cut boards are stacked automatically and can be easily removed with a pallet jack even while cutting continues.



Board loading/Board feeder

Different settings guarantee reliable board separation. A pre-positioning system ensures that every board is accurately placed on the cutting surface even with imperfectly stacked materials.

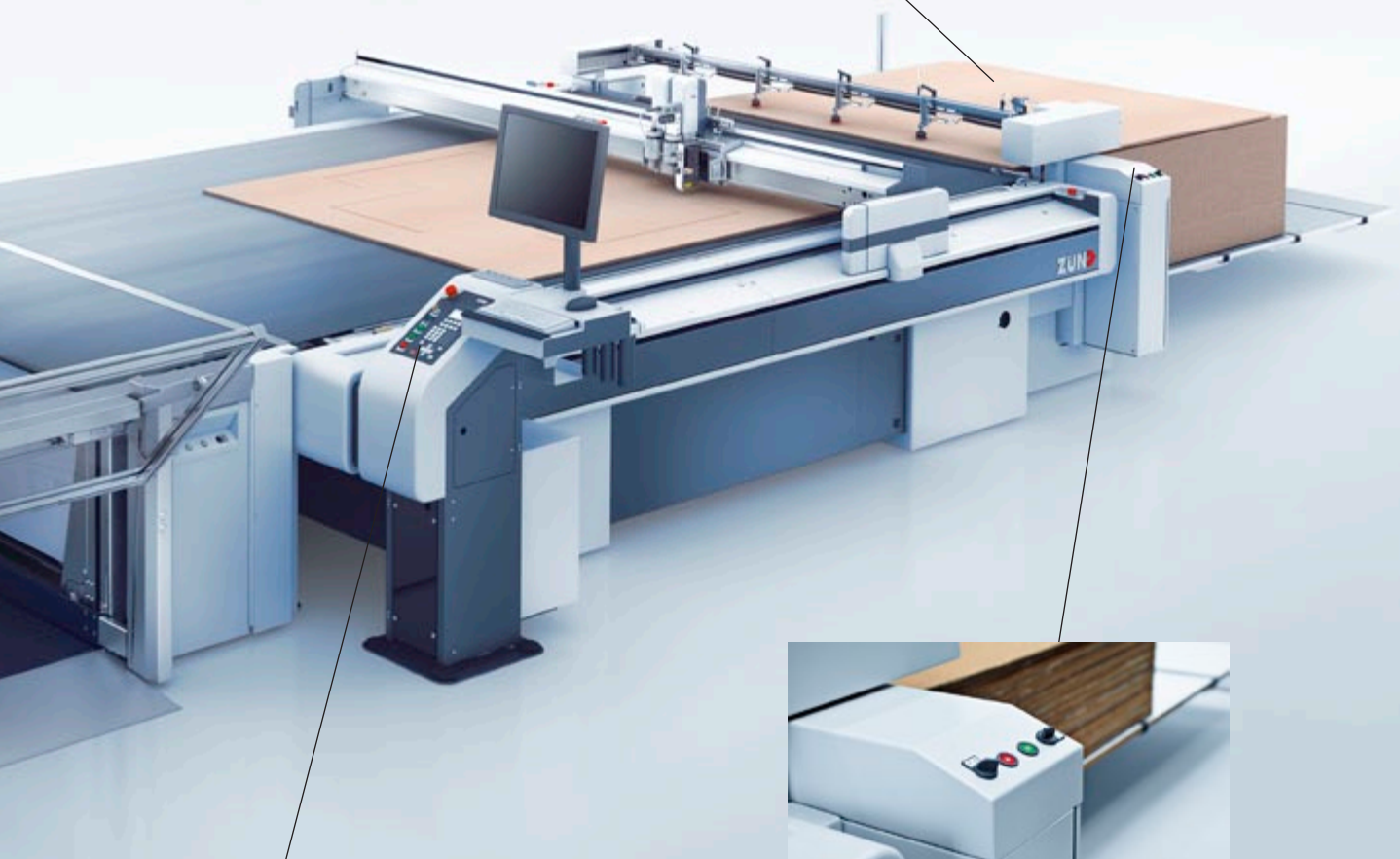

Ease of use

The controls are limited to a few basic settings easy for any operator to master.



Ergonomics

All components are easily accessible, whether for manual loading of very short runs or fully automated production. The entire system is controlled from the ergonomically designed workstation.